

Anaerobic Digestion

MEHA 2012 Annual Meeting

Craig S. Coker
Coker Composting & Consulting

Coker Composting & Consulting

- Small environmental engineering consultancy
- Over 35 yrs. experience in organic wastes recycling facility development
 - Manures, greenwaste, food scraps, sludges
 - Composting and digestion operations
 - Product marketing and sales
- B.S. Environmental Science (1975), M.S. Sanitary Engineering (1980)



Acknowledgements

- Photo credits:
 - American Biogas Council
 - BioFerm GmbH
 - CalRecycle
 - Organic Waste Systems
 - Qasar Energy Group

Topics to be Covered

- Part 1
 - The Science of Anaerobic Digestion (AD)
 - Types of Digestible Wastes
 - Types of Solid Waste AD Systems
- Part 2
 - Anaerobic Digestion Facility Management
 - AD in Massachusetts

What is Anaerobic Digestion?

- The controlled solubilization and reduction of organic materials in the absence of oxygen
- Products are methane and carbon dioxide
- Residuals are digestate, trace gases, and water

The Science of Anaerobic Digestion

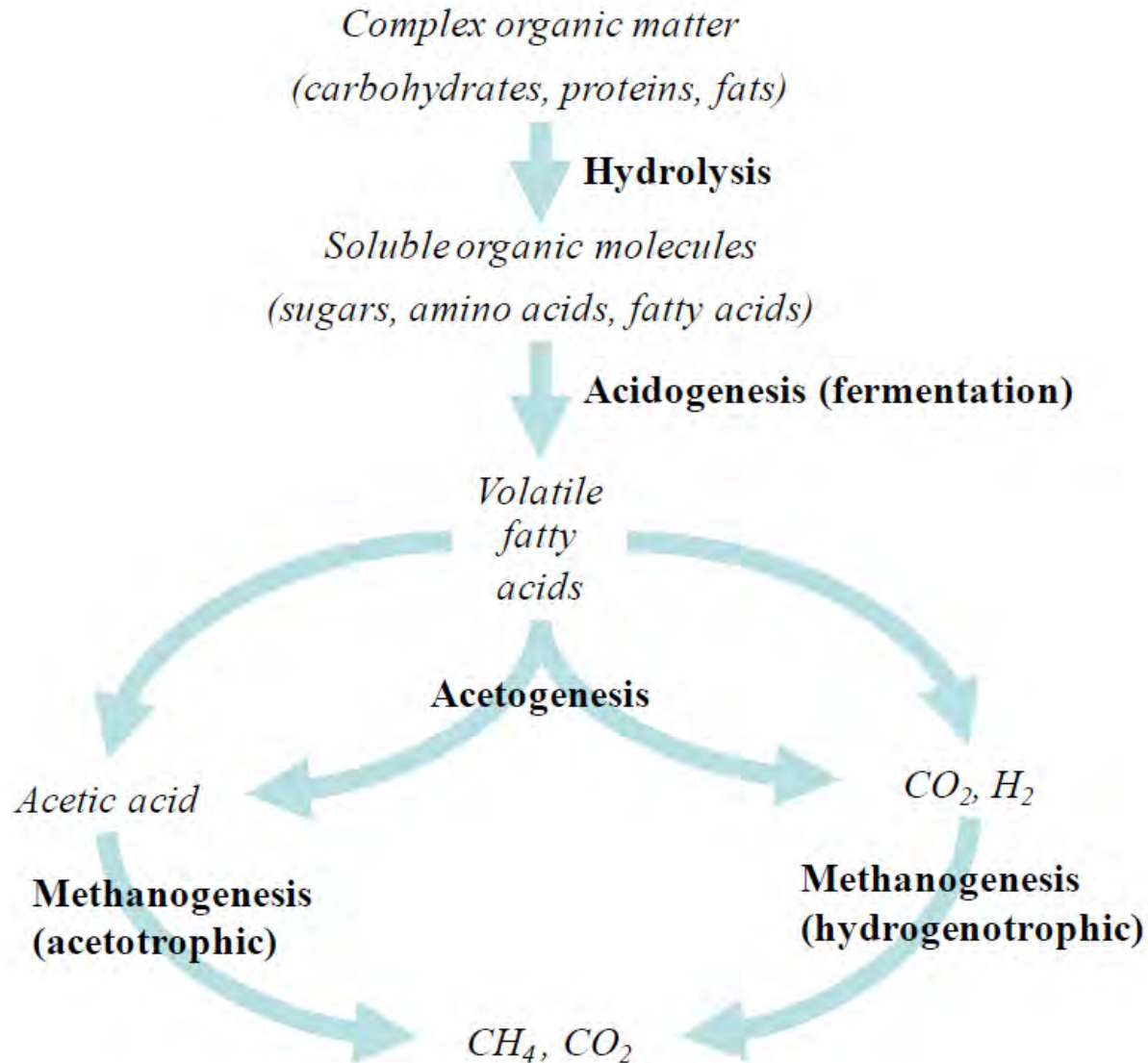

Step 1 - Hydrolysis

- Extracellular enzymatic reduction of complex organics to soluble organics

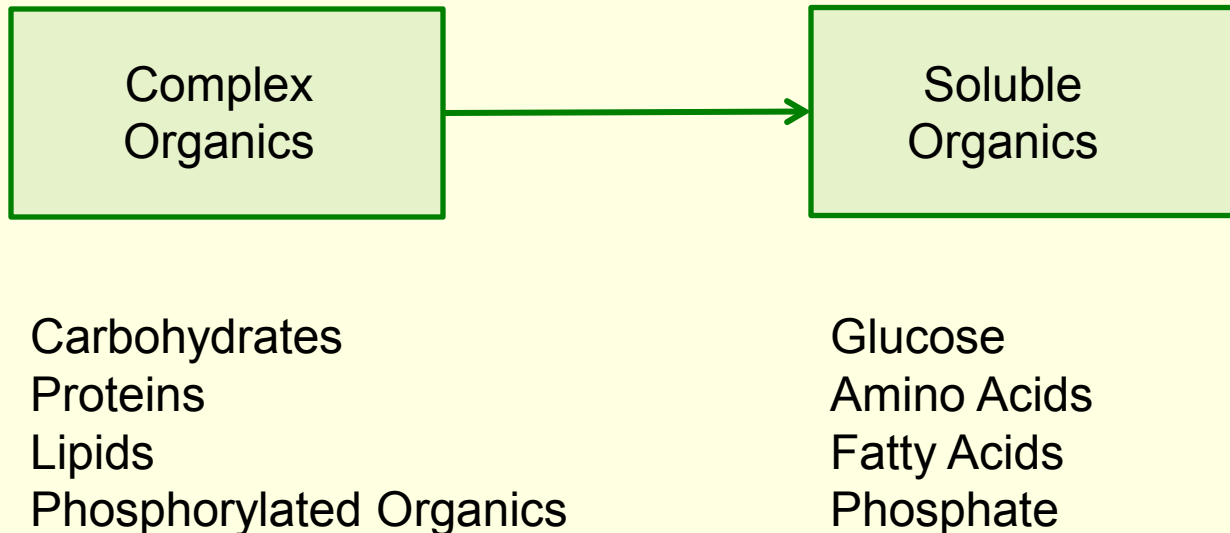

Step 2 - Acidogenesis

- Fermentation to produce volatile fatty acids

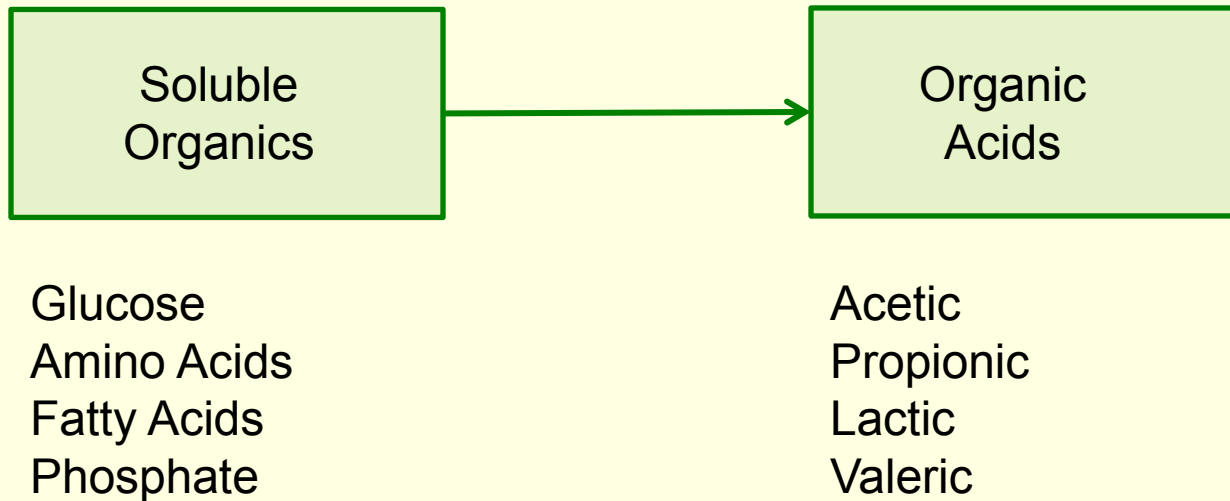

- Byproducts – NH_3 , CO_2 , H_2S

Step 3 - Acetogenesis

- Microbial metabolism of fermentation products to make acetic acid, CO₂ and hydrogen

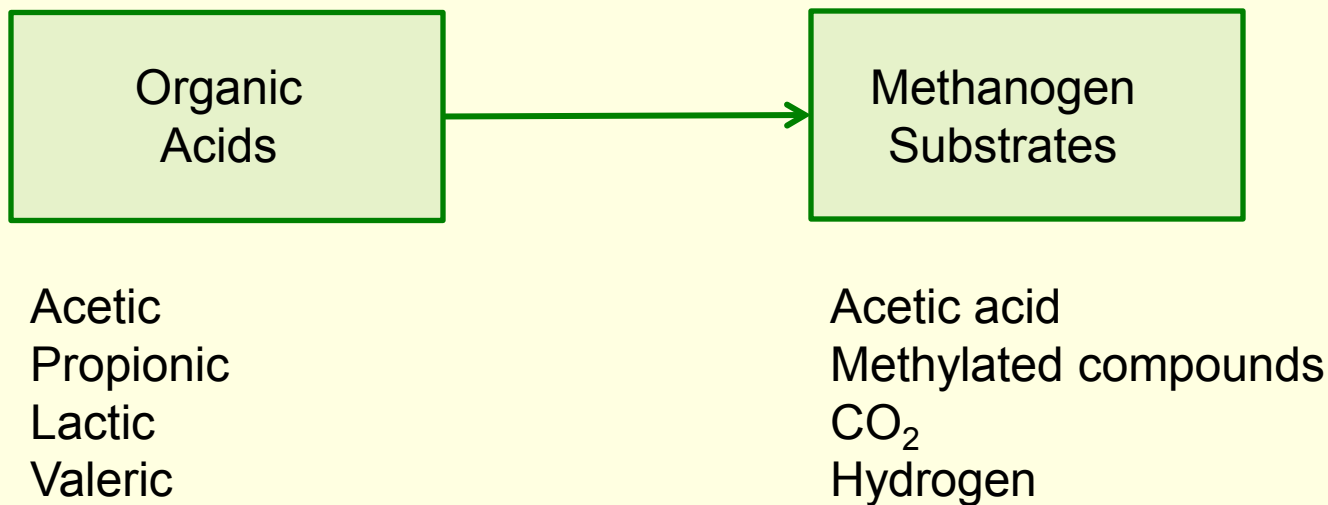

Step 4 - Methanogenesis

- Acetate, methylated substrates and hydrogen converted to methane and carbon dioxide

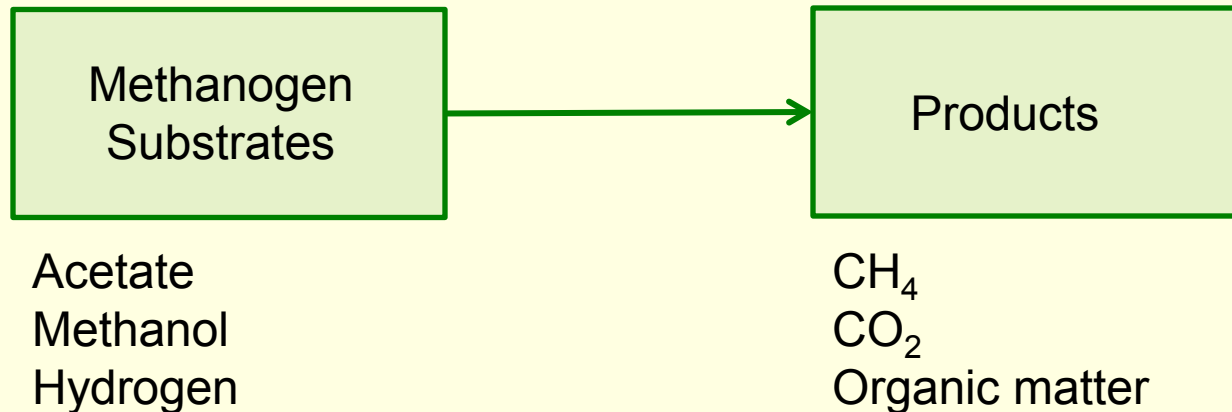

Acetotrophic methanogenesis: $4 \text{CH}_3\text{COOH} \rightarrow 4 \text{CO}_2 + 4 \text{CH}_4$

Hydrogenotrophic methanogenesis: $\text{CO}_2 + 4 \text{H}_2 \rightarrow \text{CH}_4 + 2 \text{H}_2\text{O}$

Methylotrophic methanogenesis: $4 \text{CH}_3\text{OH} + 6 \text{H}_2 \rightarrow 3 \text{CH}_4 + 2 \text{H}_2\text{O}$

Biogas

- Typically 50% - 70% CH₄
- Typically 25% - 35% CO₂
- Contaminants – amounts depend on digestible substrate composition
 - Hydrogen sulfide
 - Ammonia
 - Siloxanes (organosilicon compound)
 - More common in landfill biogas due to decomposition of personal care products

What wastes are best for biogas?

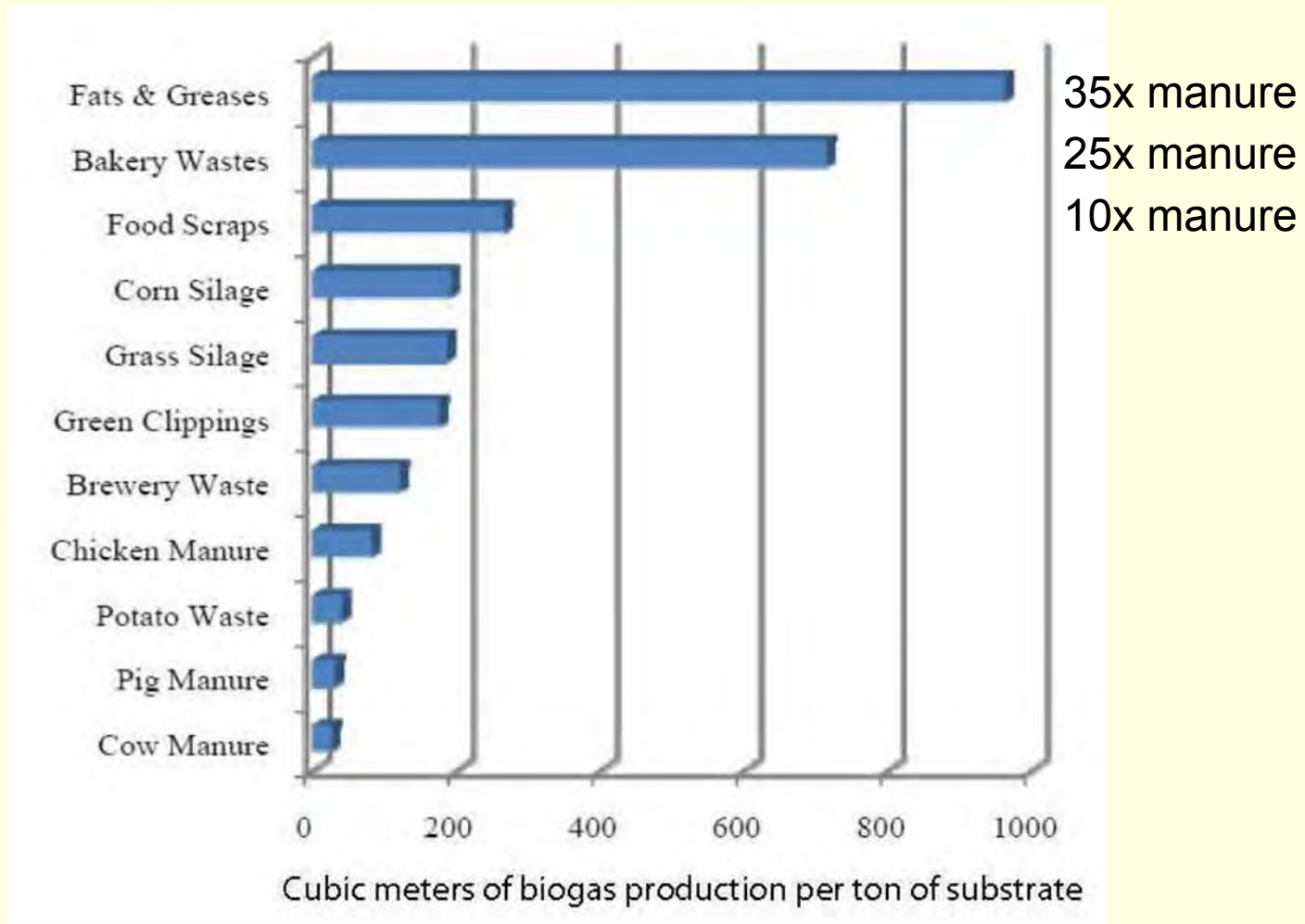



Food Scraps



Food Processing
Residuals



Biosolids



Dairy & Swine
Manure



Silage



Grease Trap
Wastes

Classifying Digesters

- Temperature range
 - Psychrophilic vs. mesophilic vs. thermophilic
- Moisture content of substrate/feedstock
 - Liquid vs slurry vs dry solids
- Number of stages
 - One stage (common) vs two-stage (separate hydrolysis/acidogenesis and methanation)

Types of AD Systems

- Psychrophilic
 - The term used for “cold” digestion at approximately 25 degrees Celsius.
 - This type is rarely used.
- Mesophilic
 - The term used for “warm” digestion at approximately 25 to 40 degrees Celsius.
 - This is the most common for European digesters.
- Thermophilic
 - The term used for “hot” digestion at approximately 52 to 55 degrees Celsius.
 - The high temperature guarantees pathogen kill.

Liquid Digesters

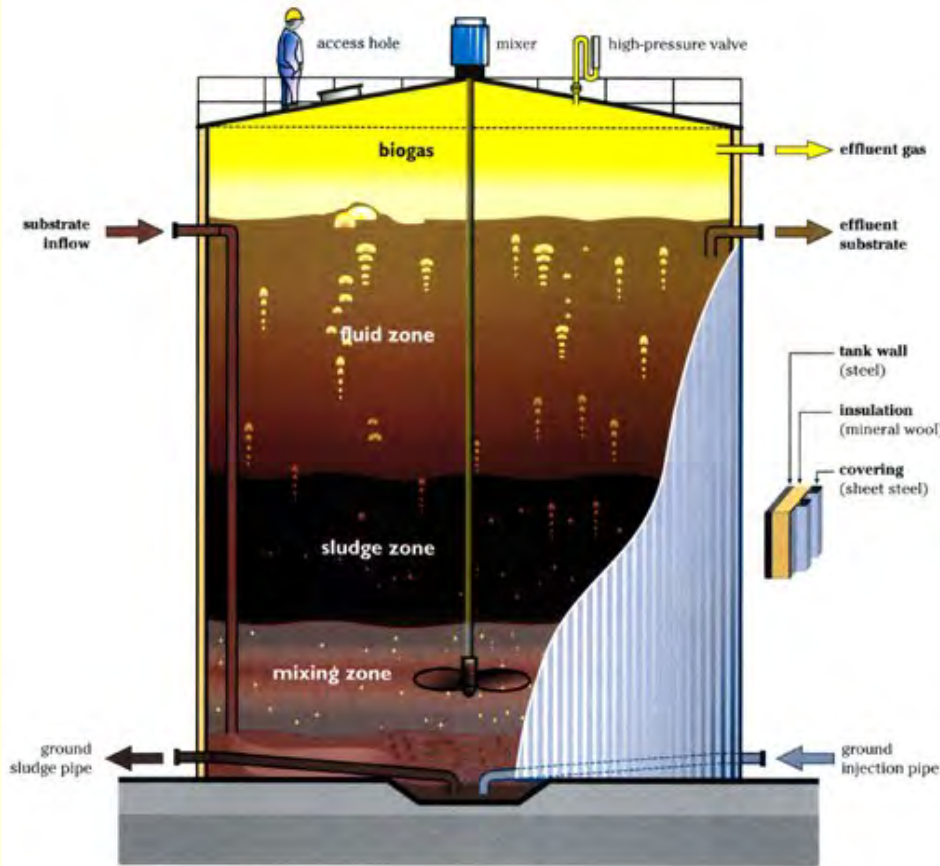

- Less than 5% total solids
- Good for sludges, manures
- Plug Flow Reactors (PFR) or Continually Stirred Tank Reactor (CSTR)

Plug Flow Reactor

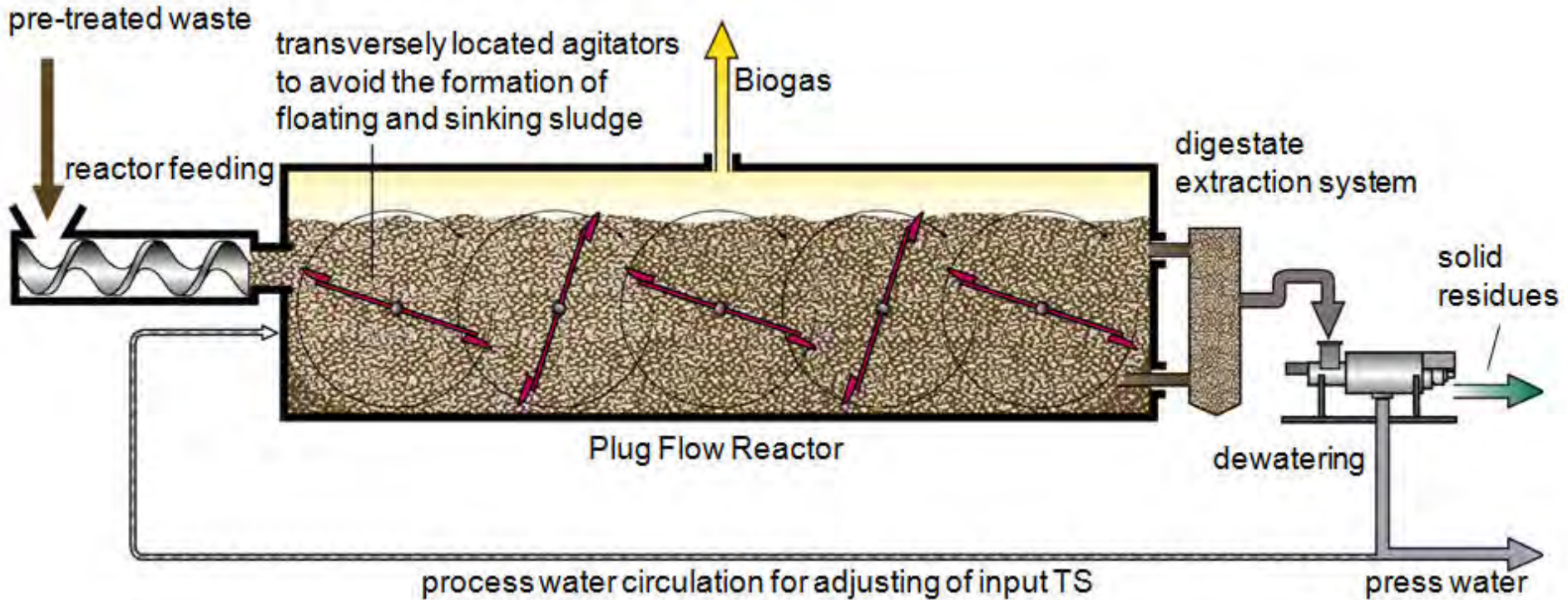

Huckabay Ridge, Texas

- 10,000 cows + fats, oils and greases from restaurants
- 2.7 million scf/day gas
- 650,000 MMBtu/year (the energy equivalent of 4.6+ million gallons of heating oil)
- Piped to CA as recycled natural gas



COLUMBUS:

System Online: 8-15-10

Electricity: 1 MW

Community & County:
Columbus, Franklin County

Managed By:
Kurtz Bros. ,Inc.

Status:
Under Construction

Capacity:
40,000 - 45,000 wet tons/year

Inputs:
Food Waste, FOG, & Biosolids

Collaborators:
Solid Waste Auth. of Central Ohio
Ohio Air Quality Dev. Authority
The City of Columbus

quasar
ECO CITY SYSTEM 1325

Slurry Digesters

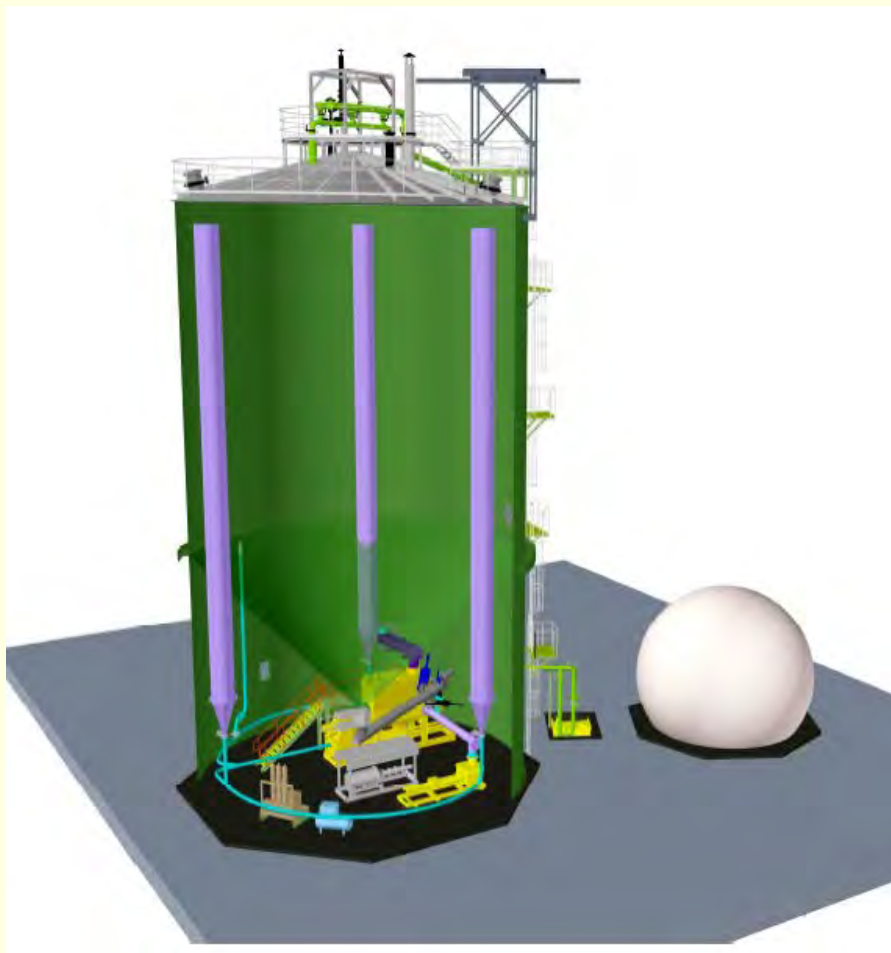

- Can handle thicker liquids (up to ~ 50% T.S.)
- Substrate pumped to top, flows downward
- High capacity on small footprint



Brecht, Belgium

- 50,000 tonnes/yr of kitchen & garden wastes
- Digester dimensions are 15 m diameter and 25 m high
- >9 million kWh/yr electricity production
- Digestate composted onsite

Solid Waste Digesters



- Also known as dry fermenters
- Solids content greater than 50% T.S.
- Batch reactors filled with loaders
- 28-day biogas generation period
- Digestate removed & composted

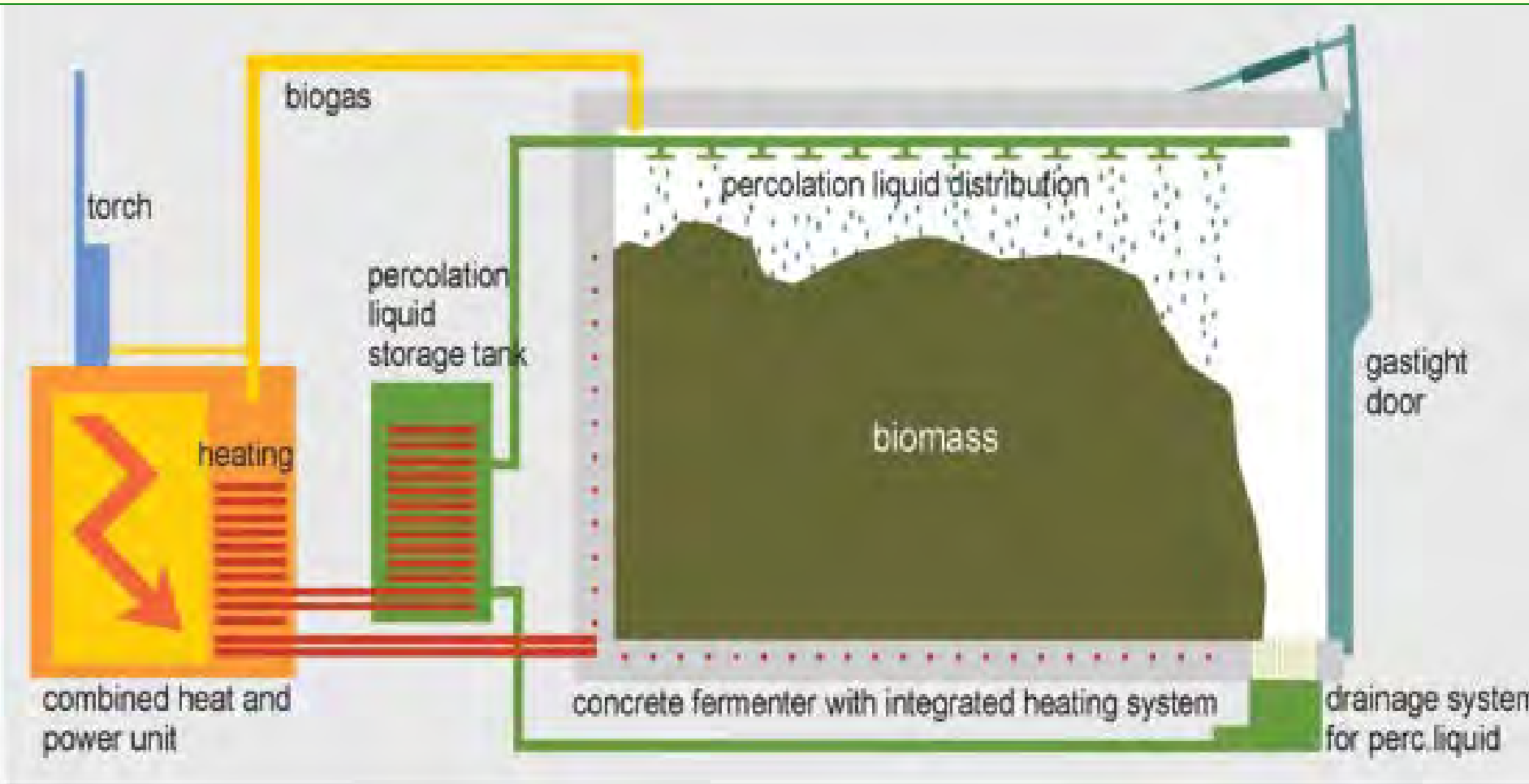





UW-Oshkosh, WI

- Opened Oct 2011
- First U.S. installation of dry fermenter
- 8,000 tons/yr capacity
- Food scraps and landscaping debris
- Will provide ~ 5% of campus heat & electricity



Hybrid Systems

- Co-digestion of two dissimilar substrates
- Food scraps digested with biosolids
 - Oakland, CA
 - West Lafayette, IN
 - Renton, WA
 - Columbus, OH

East Bay Municipal Utility District, Oakland, CA

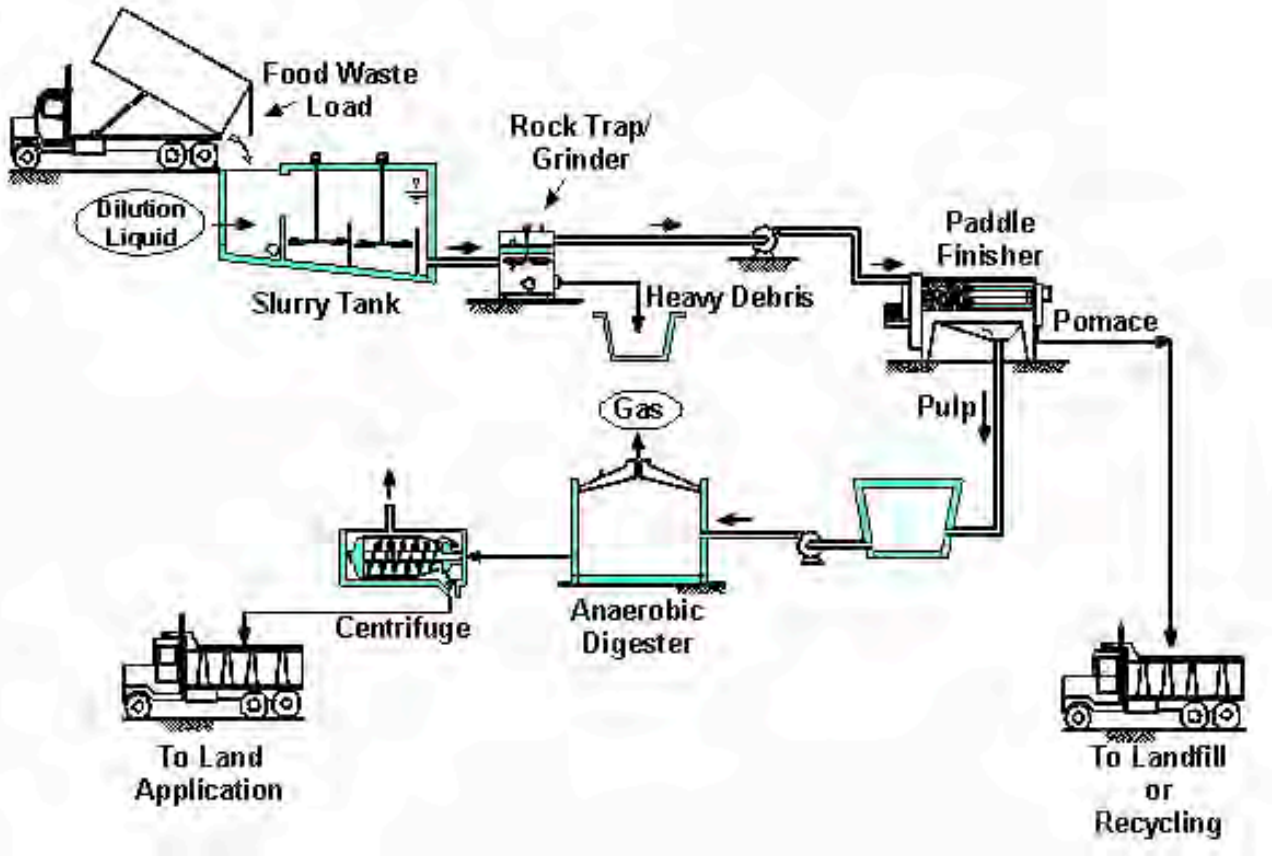

Part 2 - AD Facility Management

- Topics
 - Process Flow and Mass Balance
 - Waste Collection & Transport
 - Waste Receipt & Pre-processing
 - Digestion Process Challenges
 - Gas Generation, Clean-Up & Use
 - Digestate & Wastewater Management
 - Site Sanitation & Vector Control

Anaerobic Digestion Process Flow Diagram

Facility activities

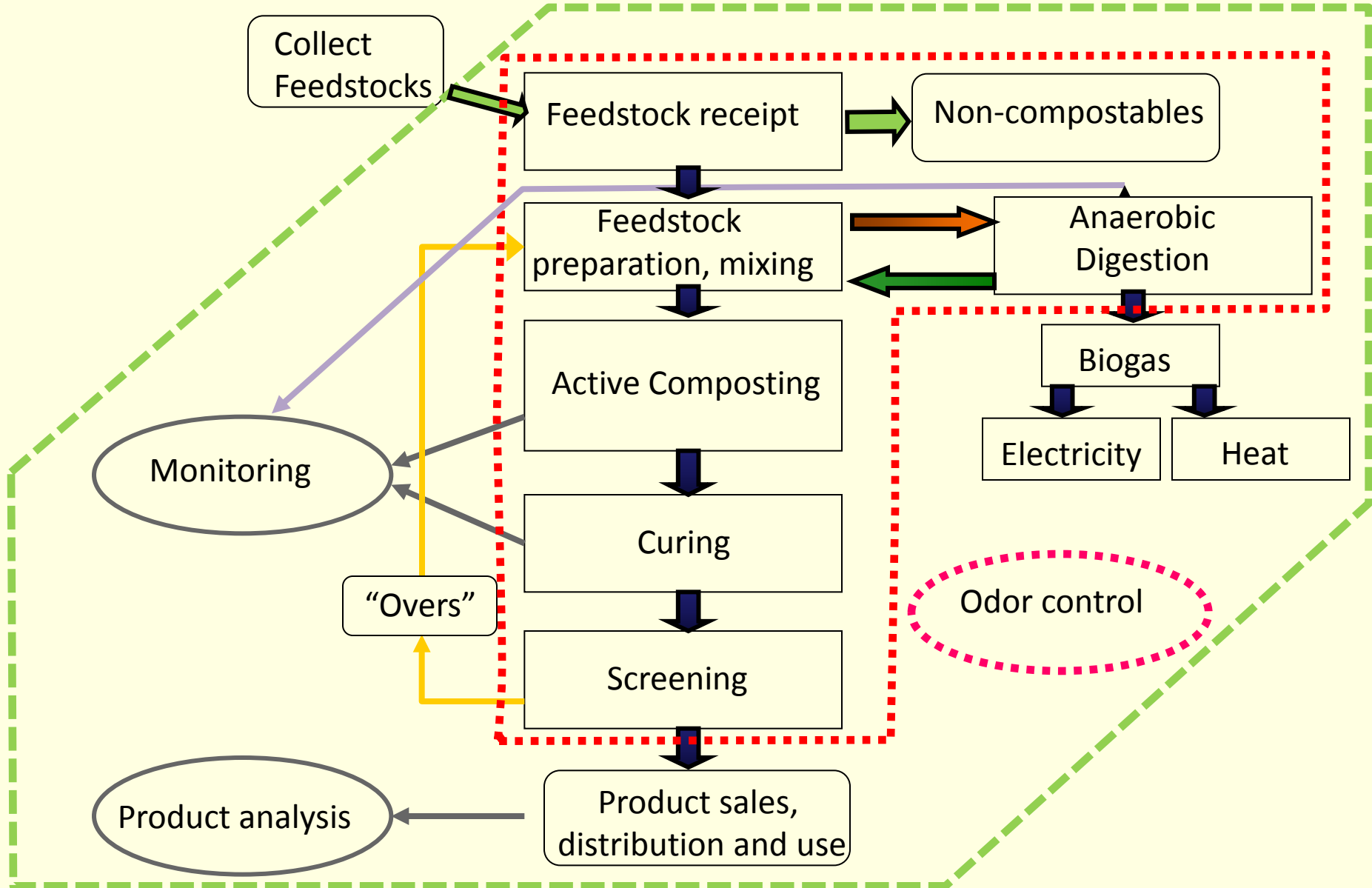

Mass Balances Through Process

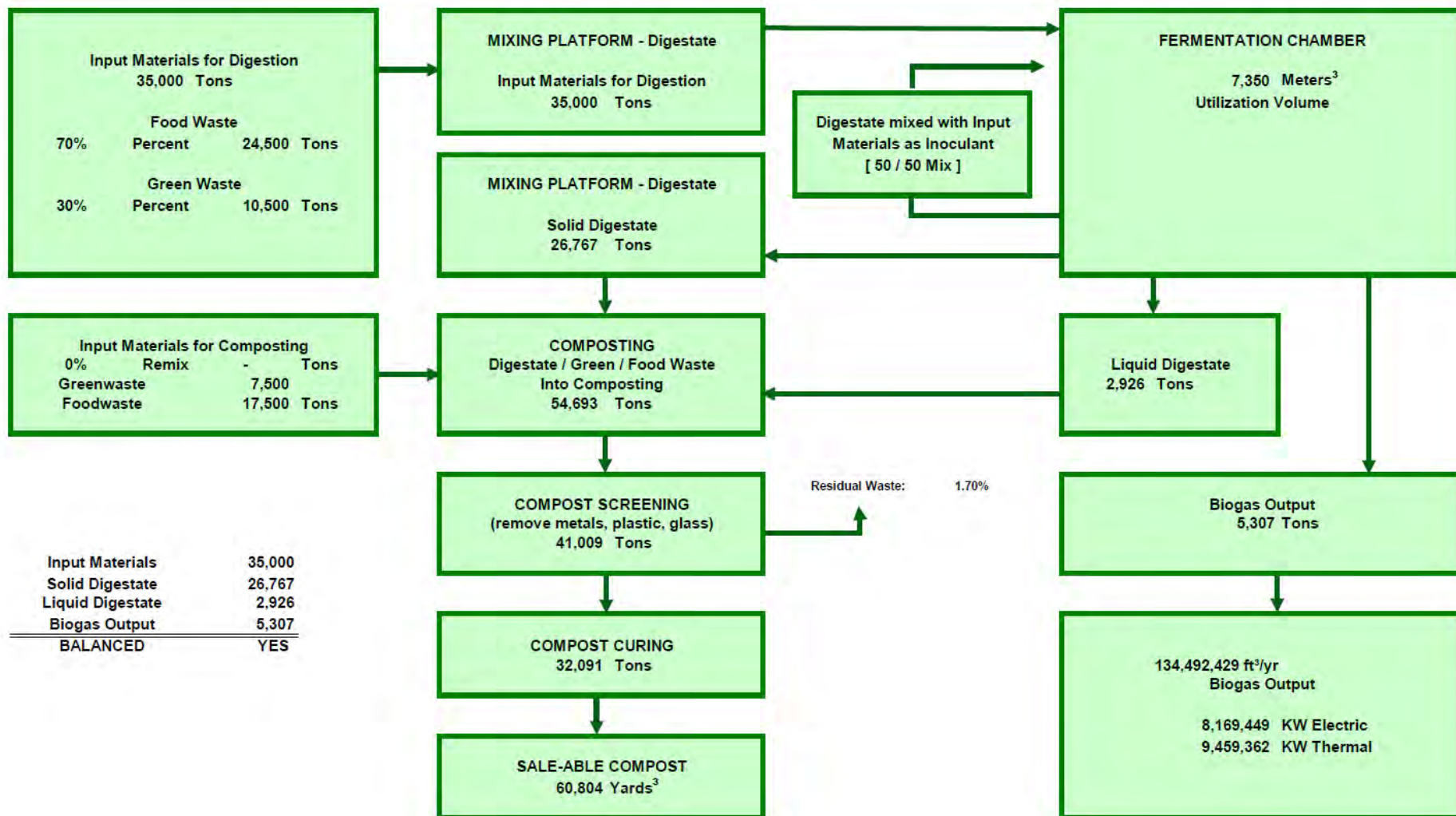

Food Scraps Diversion



Food Losses in America

- **Households – 1.28 lbs/day** (as MSW, excluding garbage disposals, BYC, scraps to the dog, etc.)
- **Fast Food Estab. – 418.4 lbs/day**
- **Full Service Restaurants – 138.2 lbs/day**
- **Supermarkets – 120.8 lbs/day**
- **C-Stores – 52.7 lbs/day**

Source: Jones, T.W., “Using Contemporary Archaeology and Applied Anthropology to Understand Food Loss in the American Food System”, University of Arizona, 2004

Food Scraps Collection

Included:

- All Food Products
 - Fruit, Vegetables, Cereal, Dairy
 - Meat, Fish, Bones
 - Leftovers, table scraps
- Coffee grounds, filters, tea bags, etc.
- Food Soiled Paper

Not Included:

- Plastic (Bags, containers, Styrofoam, etc.)
- Glass
- Metals
- Liquids

Collection System Characteristics

- Separate collection containers
- Training needed to avoid contamination
 - Minimize behavioral changes
 - High turnover means repeated training
 - Multi-language/high graphical content
- Separate collection trucks & routes
 - Not as profitable as regular trash routes due to lesser route density

Compost It!

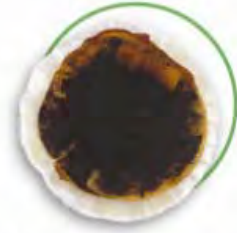

Signs By:
Good Green Graze's
 Reuse, Recycling & Composting Specialists
www.goodgreengraze.com



YOUR
 LOGO
 HERE

Copyright © 2010

COMPOST

ABONO | 堆肥

BizSMART



NO...

Garbage
 Basura

Plastics and Plastic Bags
 Artículos Plásticos y Bolsas Plásticas

Recyclables
 Artículos que Pueden Reciclarse

Sod, Dirt and Rocks
 Tierra Herbosa [Sod], Tierra y Piedras

Animal Waste
 Deshechos de Animal

Treated and Painted Wood
 Madera Pintada y Tratada con Químicos

Plywood
 Madera Contrachapado

NOT SURE?

CALL US
 (650) 595-3900 or VISIT
RecologySanMateoCounty.com

¿TIENE DUDAS? LLÁME AL (650) 595-3900
 o VISITE RecologySanMateoCounty.com

有疑問？請致電 (650) 595-3900
 或訪問 recologyxmsmateocounty.com



Rethink
waste
 Santa Barbara Waste
 Management Authority

R
Recology.
 San Mateo County
 WASTE ZERO

Dining Hall / Cafeteria – Food Prep



Note: compostable
can liners now used



Dining Hall / Cafeteria – Dish Room



- Strainer designed to capture food waste from dish-wash line



- Trays are placed on conveyor by employees
- Kitchen staff clear trays

Transporting Organics

- Sealed vehicles often necessary
- Rendering bodies or roll-offs, or
- OTR tractors with dump or live-bottom trailers
- Most use diesel, but some can be retrofitted to use RNG, if clean



Rear-loader truck with cart lifters





Some liquefaction during transport



Compactors



Photos Courtesy Whole Foods Markets, Austin Texas.

Special Events



Special Event Food Scraps Collection, City of Bakersfield Photo Kevin Barnes

Waste Receipt & Pre-Treatment

- Unloaded in Receiving Hall
 - Behind closed doors for odor control
- Source separation not 100% effective
 - Plastics contamination biggest problem
- Screening to remove contaminants
- Grinding/shredding for particle size reduction



ORGAWORLD
CANADA LTD

2

Waste Receiving Hall

**Plastics contamination
higher in residential
curbside collected
materials**





**Mostly pre-consumer food scraps
with lesser plastics contamination**





Larger contaminants screened out



High-torque, low-speed shredder



Shredded source-separated biowaste

Shredder rejects



Digestion Process Challenges

- Nutrient balance important to microbial health
 - Excess N → ammonia toxicity
- Optimum conditions
 - Near-neutral pH
 - Constant temperature
 - Mesophilic – 30-40°C.
 - Thermophilic – 50-60°C.
 - For liquid/slurry digesters, constant feed rate

Solid Waste Digesters

- Leachate (“percolate”) used to soak biomass in reactor
- Distributes nutrients, dilutes toxins
- Liquid in pore spaces inhibits O₂ transfer & promotes anaerobic conditions
- Biogas extracted through vents
- Not as subject to process upsets as liquid/slurry digesters

Percolate storage tank



Heat Exchanger

Percolate Spray Nozzle



Gas extraction port



Gas Recovery & Usage



SMARTFERM[®] dry fermentation

The yield determination is so simple.

Enter the required data in the calculator. You immediately obtain information about the expected yields.

Substrate group	Substrate	Mass	Dry substances	Organic dry substances	Density	Biogas recovery	CH4
1 Waste	Commercial organics	3000 t/a	35 %	80 %	0.55 t/m ³	120 m ³ /t	55 %

[Add another substrate](#)

Total substrate mass: 3000 t/a



Output

Digestate	Biogas	Mean CH4 content
2653 t/a	264000 m ³ /a	55 %

Energy yield if CHP is applied

Specifications of CHP manufacturer

Electrical efficiency: 38%

Thermal efficiency: 40%

Filling level: 99%

Power output (kWh/a), total: 564 300 kWh/a

Heat output (kWh/a), total: 594 000 kWh/a

Gas Composition

- Biogas basically consists of the following compounds:
 - CH₄ 40 ~ 70 Vol%
 - CO₂ 25 ~ 55 Vol%
 - H₂S 0 ~ 5000 ppm
 - NH₃ 0 ~ 1 Vol%
 - H₂O 0 ~ 10 Vol%
 - N₂ 0 ~ 5 Vol%
 - O₂ 0 ~ 2 Vol%
 - H₂ 0 ~ 1 Vol%

Gas Clean-Up

- Extent depends on end usage
- Electricity production
 - Via CHP, micro-turbine, or fuel cell
 - Condense water out, limit H₂S to <50 ppm
- Inject into gas pipeline or vehicle fuel
 - Same as above plus remove CO₂
 - For pipelines, may have to add propane and/or mercaptans

Biological Desulfurization with *Sulfobacter oxidans*

PROCESS :

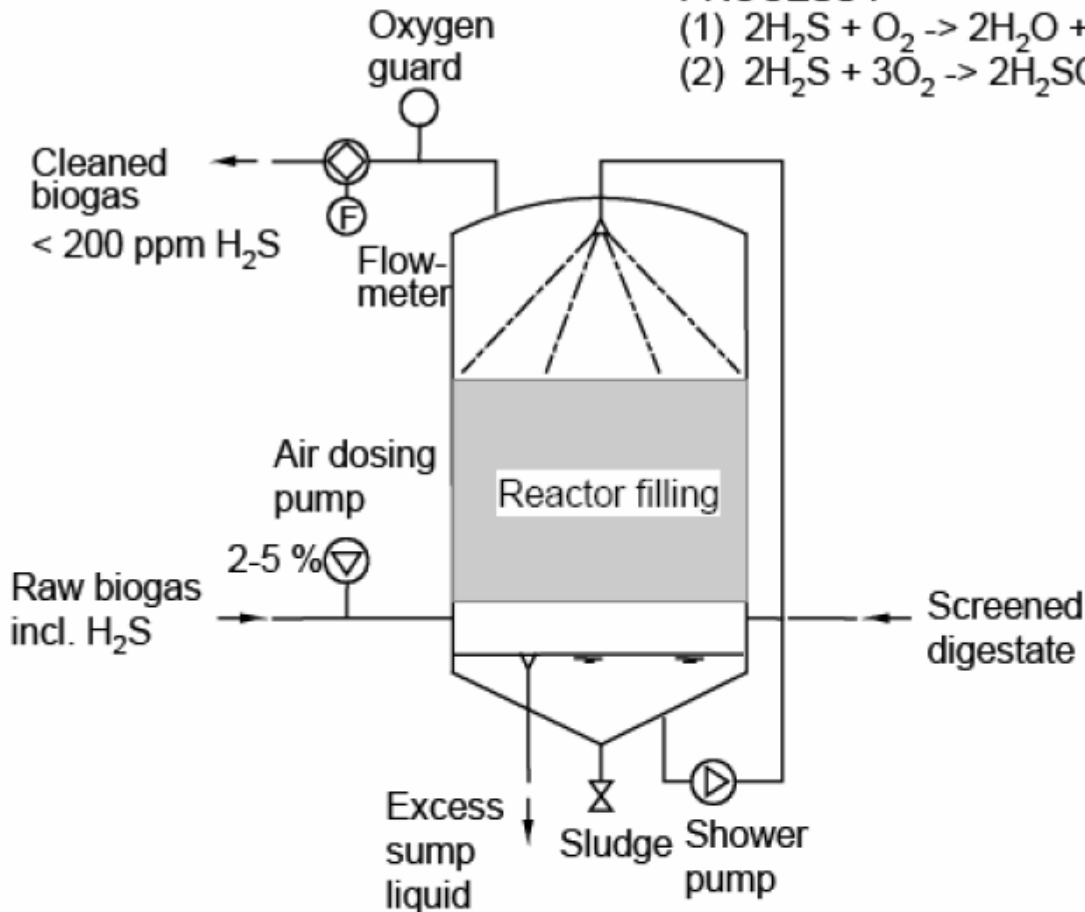
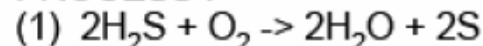

Process Flow Diagram for Pipeline Injection Biogas Cleaning System

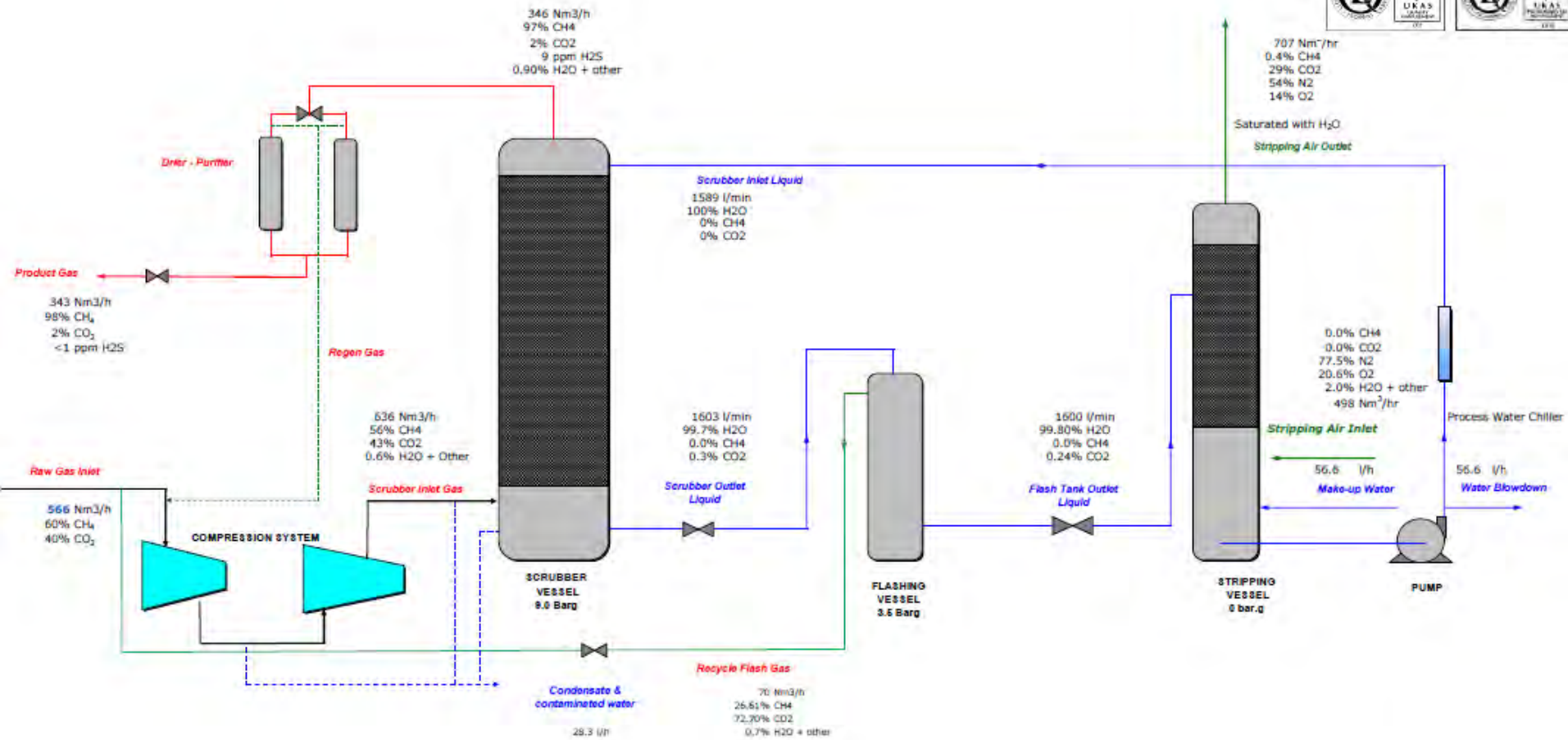

Electricity Generation from Biogas

- Assuming a Combined Heat-and-Power (CHP) gen-set
 - AD system capacity = 3,000 tons/yr
 - CHP energy efficiency = 38%
 - Electrical production = 564,300 kWh/yr
- If the average house consumes 14,000 kWh/yr (1,166 kWh/month), system will provide power for 40 homes.



Heat Recovery

- CHPs are only ~ 40% efficient
- Capturing waste heat from engine jacket and exhaust can raise system efficiency to 80%+
- In our example, 3,000 tons/yr AD of commercial organics
 - Heat recovery potential = 2,025 mmBTU/yr
 - Enough heat to raise the temperature of 4 Olympic swimming pools 100° F. each.

Recovered Heat Uses

- Heat percolate tank or digester tanks
- Space heating
- Greenhouse heating for crop production
- Sell to nearby industrial user

Digestate Management



- Residual after digestion
- Often called “fiber”
- Liquid digestates usually dewatered to save haul costs

Dewatered dairy
manure digestate

Silage and manure digestate



**Digestate from food scraps dry
fermentation system**



Digestate Uses

- Liquid fraction
 - Land application to crops
 - Crop fertilizer
- Dewatered fraction
 - Animal bedding
 - Land application to crops
 - Feedstock to composting
 - Peat substitute in growing media
 - Dry and pelletize for fertilizer market

Digestate Issues

- Pathogen kill for mesophilic digesters
- Odors from volatile fatty acids
- NH_3 and CH_4 emissions for 3 months
 - If not processed by composting or drying, covered storage recommended
- NH_3 concentration in filtrate after dewatering ($\sim 4\%+$) can cause disposal issues

Site Sanitation & Vector Control

- Challenging –
 - Wet, putrescible materials on-site
 - Outdoor portions of facility subject to puddles of organics-enriched rainfall runoff
 - Spillage of materials moved by loaders
- Key is aggressive housekeeping



Spillage being cleaned up

AD in Massachusetts

- Jordan Dairy Farm, Rutland MA



AGreen Energy/Jordan Dairy Farm

- Feedstocks
 - Slurried food scraps, Fats/Oils/Greases (FOG), Source Separated Organics, food processing residues
- System Capacity: 550,000 gallon
- Annual Electricity: 2,280 MWh
- Incoming Biomass Storage: 3 days (approx.)
- Normal Digestion Time: 28 days (approx.)
- Annual Inputs: 15,148 wet tons
- Technology: liquid digester provided by Qasar Energy (Ohio)

Future AGreen Projects

- South Deerfield, MA
- Hadley, MA
- Both similar to Rutland
- Both permitted by MA DEP

Other AD projects in MA

- Sewage sludge (only 6 of 133 WWTPs)
 - Boston, Lawrence, Clinton, Rockland, Pittsfield, Fairhaven
- Industrial Wastewater
 - Coca-Cola in Northampton
 - Garelick Farms Dairy in Lynn
- Others waiting for MA DEP regulatory revisions to be finalized

MA DEP Regulatory Revisions

- 2010-2020 Solid Waste Master Plan, “The Pathway to Zero Waste”

“Reduce solid waste disposal by 30% by 2020, from 6,550,000 tons of disposal in 2008 to 4,550,000 tons of disposal by 2020.”

“By 2050, Massachusetts residents and businesses should reduce the amount of waste they produce by 80%, and virtually eliminate products containing toxic chemicals from our disposal facilities.”

“Eliminate Barriers to Siting Recycling and Composting Facilities – Modify MassDEP’s siting regulations to eliminate barriers to siting facilities that support increased recycling and composting, as well as other facilities such as anaerobic digestion facilities that generate energy from source separated organic materials. Maintain strict facility oversight to ensure a high level of environmental performance.”

“Work with interested parties (municipalities and/or businesses) to develop integrated solid waste management systems that achieve our objective of maximizing recycling and composting and minimizing residual materials in need of disposal.”

”Pilot innovative approaches that achieve our objective of improving the environmental performance of solid waste facilities, can divert 100% of waste materials from disposal, and help achieve the goal of zero waste at a local and regional level.”

Task Force on Building Organics Capacity

- Formed February 2011
- Goals:
 - Identify the barriers to advancing management of organic material in Massachusetts,
 - Identify ways to reduce or eliminate these barriers, and
 - Recommend specific actions to expand the infrastructure for composting, recycling, and organics management

Task Force Conclusions

- Technologies for composting, AD and organics recycling much evolved over past 30 years
- MA Site Assignment Law (M.G.L. chapter 111, §150A and §150A ½) and Regulations (310 CMR 16.00) overdue for updating
 - Designed for landfills and transfer stations
 - 15 tons/day max off-site input for composting exemption
 - No mention of AD
 - Larger recycling facilities can obtain a “Determination of Need” (DON) that a Site Assignment from Board of Health not needed

Prop. Amendments to 310 CMR 16.00

- Establish that facilities handling certain organic or recyclable materials that have been separated from waste, and which will recycle, compost or convert these feed stocks into new products or energy would not be considered “solid waste management facilities”, and would therefore be exempt from Site Assignment;
- Establish levels of MassDEP review and oversight for these facilities that are commensurate with and appropriate for the environmental and public health issues that they present, and that will ensure that these facilities are properly constructed and managed to avoid public health and environmental impacts; and
- Establish clear permitting pathways for facilities that would require site-specific MassDEP approvals.

Rationale for Amendments

- Any facility managing solid waste from municipal, commercial or construction sources is a “solid waste management facility” and must obtain a Site Assignment.
- Materials that have been separated or sorted from solid waste (“pre-sorted”) and are used as feed stocks to manufacture products will not be regulated as “solid waste”, and the operations that use these materials will not be regulated as “solid waste management facilities”.
- Residuals remaining after organic or recyclable materials have been separated from the waste are considered to be “solid waste”.
- The operations that are managing pre-sorted materials must ensure that the quality of both the incoming pre-sorted materials and their outgoing products are suitable for their intended purposes.
- Operations managing pre-sorted materials must ensure that the pre-sorted materials they accept for use as feed stocks contain only incidental levels of toxic substances that will not cause the operation’s products to pose a threat to public health, safety or the environment.
- The operations must be constructed and operated to meet MassDEP’s standards for protection of public health and the environment, and for the prevention of public nuisances.
- MassDEP’s process for permitting operations to manage pre-sorted materials must provide for adequate public review and comment on permits.

Status of Revisions

- Public Comment period closed on Jan. 23, 2012
- 37 comments received
- MassDEP expects revised regulations to go final in 3rd Qtr. 2012¹

¹Personal communication, Mr. James Doucette, MassDEP, April 20, 2012

A close-up photograph of a pair of weathered, brown hands cupping a small, vibrant green seedling with four leaves. The seedling is growing out of a mound of dark, rich soil. The background is a dark, textured surface, possibly more soil. The lighting is dramatic, highlighting the texture of the hands and the freshness of the plant.

Thank You!

Craig Coker
Coker Composting & Consulting
(540) 890-1086
cscoker@verizon.net
www.cokercompost.com